

Type TK16 CNG

Patented fuelling nozzle for CNG refuelling to be connected and disconnected at self-serve fuelling stations (DN 8 mm)

Type TK16 CNG is very light in weight and therefore easy to operate. It has a guide bush to protect the vehicle receptacle and an integrated swivel design located at the operating

handle which can easily be turned into the optimal actuating position. The lightweight design of the TK16 CNG means that less effort is needed to actuate the nozzle giving a smaller

operating handle and a more compact design.

Features:

- Super light → only 1750 grammes
- WEH-EASY-TURN® swivel joint 360° for operating handle
- Easy operation
- Extremely high flow rate → short filling times
- Recirculation of vented gas
- High-grade materials
- Coding for pressure range and gas type
- Option: Interface for data transfer vehicle / fuelling station



TK16 CNG with mounting

Safety

TK16 CNG offers high safety standards for the operator. The nozzle remains connected to the receptacle until the gas between inlet valve and receptacle is depressurized.

To achieve optimum performance it is recommended that the WEH-TN1 receptacle be used with the TK16 CNG fuelling nozzle.

For further information on the filling hoses (filling and venting hoses) refer to page 46 of catalogue No. 15.

Type TK16 CNG

Technical Data:

Application:

CNG fast filling of cars at self-serve fuelling stations. Fuelling Nozzle TK16 CNG designed to be used with receptacles acc. to NGV1 standard.

Pressure range:

B200 acc. to ISO 14469,
PN = 200 bar
PS = 300 bar
PT = 450 bar
Compatible NGV1, P30

Design:

All parts corrosion-resistant, with plastic thermal protection and gas recirculation. Optionally without gas recirculation as type TK5 CNG (see page 12). Seals natural gas compatible.

Temperature range:

-40°C up to +85°C

Registration:

PED97/23EC: CE 0036

Dimensions (mm):

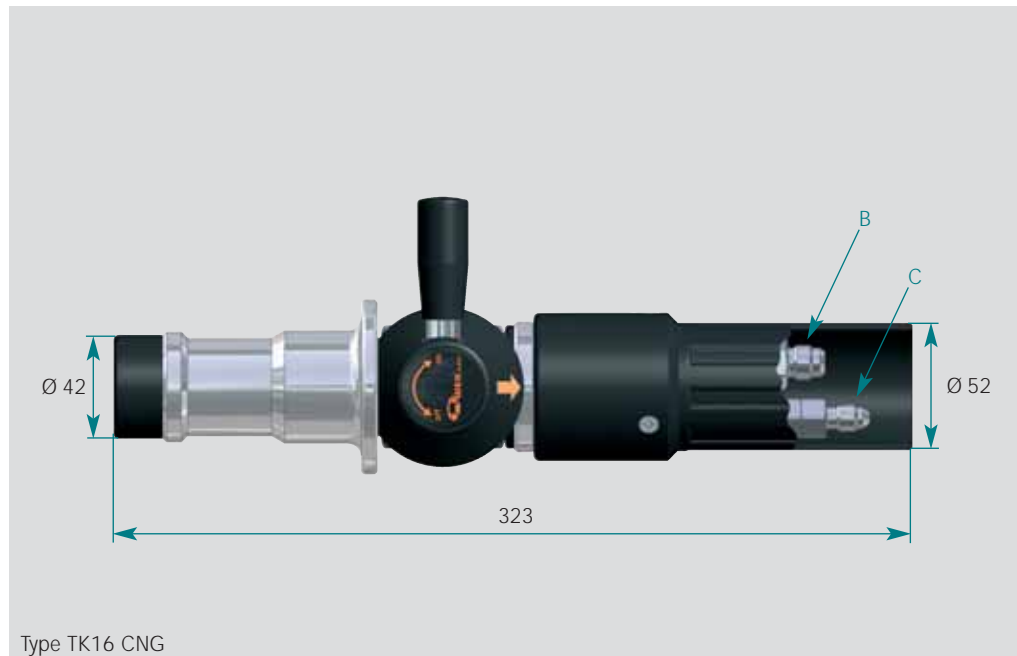

Ordering:

Description	Inlet B	Gas recirculation C	Part No.
TK16 CNG	UNF 9/16" -18* external thread	UNF 7/16" -20* external thread	C1-35299
Mounting (switch actuated)	_____	_____	C1-51233
Mounting (not switch actuated)	_____	_____	C1-51236

* acc. to SAE J514, 37°

Manufacturer:
WEH GmbH
Gas Technology

Siemensstraße 5
89257 Illertissen/Germany

Phone: +49 7303 95190-0
Fax: +49 7303 95190-9999

Email: sales@weh.com
http://www.weh.com

© All rights reserved, WEH GmbH 2009. Any unauthorized use is strictly forbidden. Subject to alteration. No liability will be assumed for any content. Herewith previous versions are no longer valid.